

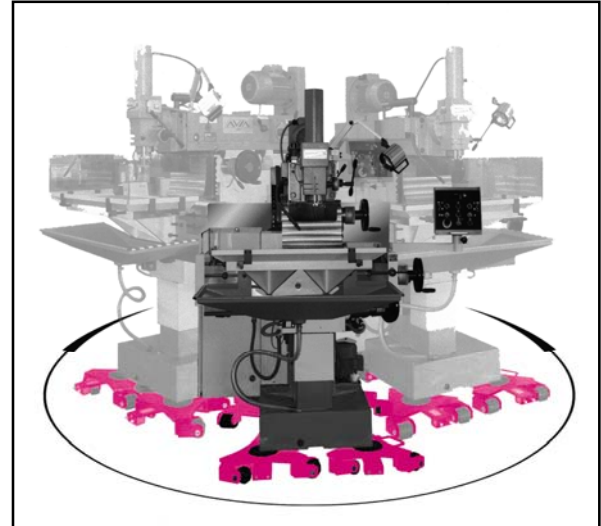

Lifting and Moving Solutions

**OPERATING AND MAINTENANCE INSTRUCTIONS No. 09 / 2011 FOR GKS-PERFEKT
TRANSPORT DOLLIES TYPE F, L, RL, TL, HF and HL**

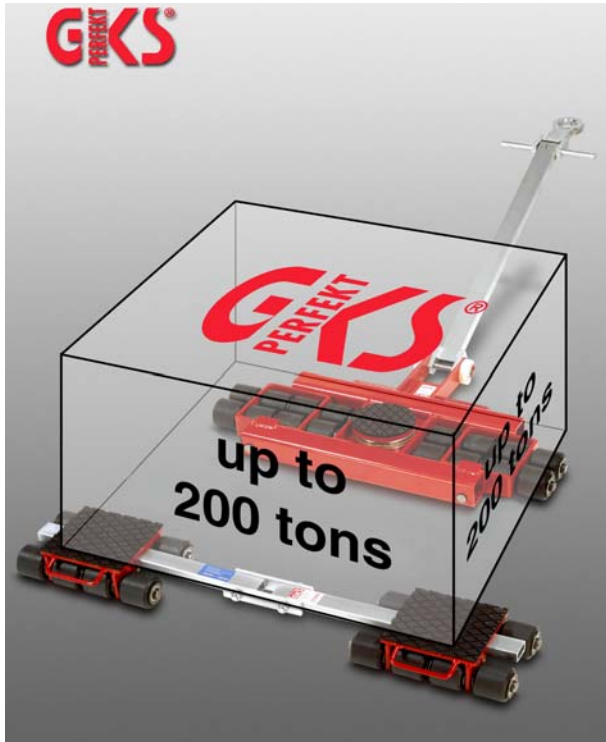

CONTENTS

▪ Test certificate	1
▪ Sales and service	1
▪ Outline of dolly types	2
▪ General safety instructions	3
▪ Special safety instructions	4
▪ Work steps	5
- Loading	
- Lifting and supporting	
- Transport	
- Unloading	
- Examples for four-point support	
▪ Repair instructions	6
- Changing the rollers	
- Replacing the honeycomb rubber supports	
- Replacing the ball thrust bearing	
- Replacing the tapered roller bearing	
- Examples	
▪ Other instructions	7
- Service, repair and spare parts orders	
- Inspection	
- Guarantee	
- Special models	
▪ EC conformity declaration	7

TEST CERTIFICATE



SALES AND SERVICE

GKS LIFTING AND MOVING SOLUTIONS LLC

Distributed by Tri-State Rigging Equipment
sales@tsriggingequipment.com
www.tsriggingequipment.com
 Tel: (314) 869-7200





Lifting and Moving Solutions

**OPERATING AND MAINTENANCE INSTRUCTIONS No. 09/ 2011 FOR GKS-PERFEKT
TRANSPORT DOLLIES TYPE F, L, RL, TL, HF and HL**

OUTLINE OF DOLLY TYPES

Dolly type / install. height in mm / inch	Total no. of rollers / Ø in mm / inch	Track gauge / distance in mm / inch	Load cap. in t / lb.	Full load capacity in t / lb.
Transport dollies F and L				
F3 / 110 / 4.3	4 / 85 / 3.3	300 / 11.8 - 1000 / 39.4	3 / 6,600	6 / 13,200
L3 / 110 / 4.3	4 / 85 / 3.3		3 / 6,600	
F6 / 110 / 4.3	8 / 85 / 3.3	620 / 24.4 - 1300 / 51.2	6 / 13,200	12 / 26,400
L6 / 110 / 4.3	8 / 85 / 3.3		6 / 13,200	
F9 / 110 / 4.3	12 / 85 / 3.3	600 / 23.6 - 1400 / 55.1	9 / 19,800	18 / 39,600
L9 / 110 / 4.3	12 / 85 / 3.3		9 / 19,800	
F12 / 110 / 4.3	16 / 85 / 3.3	740 / 29.1 - 1500 / 59.1	12 / 26,400	24 / 52,800
L12 / 110 / 4.3	16 / 85 / 3.3		12 / 26,400	
F18 / 110 / 4.3	16 / 85 / 3.3	740 / 29.1 - 1500 / 59.1	18 / 39,600	36 / 79,200
L18 / 110 / 4.3	16 / 85 / 3.3		18 / 39,600	
F20 / 180 / 7.1	16 / 140 / 5.3	610 / 24.0 - 1600 / 63.0	20 / 44,000	40 / 88,000
L20 / 180 / 7.1	16 / 140 / 5.3		20 / 44,000	
*F20 / 180 / 7.1	8 / 140 / 5.3	610 / 24.0 - 1600 / 63.0	20 / 44,000	40 / 88,000
*L20 / 180 / 7.1	8 / 140 / 5.3		20 / 44,000	
F25 / 110 / 4.3	24 / 85 / 3.3	740 / 29.1 - 1500 / 59.1	25 / 55,000	50 / 110,000
L25 / 110 / 4.3	24 / 85 / 3.3		25 / 55,000	
F30 / 180 / 7.1	12 / 140 / 5.3	830 / 32.7 - 1820 / 71.7	30 / 66,000	60 / 132,000
L30 / 180 / 7.1	12 / 140 / 5.3		30 / 66,000	
F40 / 180 / 7.1	16 / 140 / 5.3	830 / 23.7 - 2020 / 79.5	40 / 88,000	80 / 176,000
L40 / 180 / 7.1	16 / 140 / 5.3		40 / 88,000	
F60 / 180 / 7.1	24 / 140 / 5.3	1100 / 43.3 - 2730 / 107.5	60 / 132,000	120 / 264,000
L60 / 180 / 7.1	24 / 140 / 5.3		60 / 132,000	
Combination with TANDEM dolly				
F40 / 240 / 9.4	16 / 200 / 7.9	1050 / 41.3 - 2360 / 92.9	40 88,000	80 / 176,000
TL 40 / 240 / 9.4	16 / 200 / 7.9	1600 / 63.0	40 / 88,000	
F50 / 205 / 8.1	32 / 140 / 5.3	1300 / 51.2 2730 / 107.5	50 / 110,000	100 / 220,000
TL50 / 205 / 8.1	32 / 200 / 7.9	1900 / 74.8 - 2200 / 86.6	50 / 110,000	
F100 / 430 / 6.9	16 / 300 / 11.8	870 / 34.3 - 2300 / 90.6	100 / 220,000	200 / 440,000
TL100 / 430 / 6.9	16 / 300 / 11.8	2300 / 90.6	100 / 220,000	
TANDEM dolly for loads with four-point supports				
TL6 / 110 / 4.3	8 / 85 / 3.3	550 - 1150 / 45.3		6 / 13,200
TL12 / 110 / 4.3	16 / 85 / 3.3	660 - 1000 / 39.4		12 / 26,400
TL20 / 180 / 7.1	16 / 140 / 5.3	1260 - 1600 / 63.0		20 / 44,000
Transport dollies with hydraulic roller balancing system				
HF15 / 180 / 7.1	12 / 140 / 5.3	420 / 16.5 - 1500 / 59.1	15 / 33,000	30 / 66,000
HL15 / 180 / 7.1	12 / 140 / 5.3		15 / 33,000	
HF25 / 180 / 7.1	16 / 140 / 5.3	800 / 31.5 - 2000 / 78.7	25 / 55,000	50 / 110,000
HL25 / 180 / 7.1	16 / 140 / 5.3		25 / 55,000	
Rotating dollies				
RL2 / 110 / 4.3	3 / 85 / 3.3		2 / 4,400	2 / 4,400
RL3H / 170 / 6.7	3 / 140 / 5.3		3 / 6,600	3 / 6,600
RL4 / W 110 / 4.3	5 / 110 / 4.3		4 / 8,800	4 / 8,800



Lifting and Moving Solutions

**OPERATING AND MAINTENANCE INSTRUCTIONS No. 09 / 2011 FOR GKS-PERFEKT
TRANSPORT DOLLIES TYPE F, L, RL, TL, HF and HL**

KEEP OPERATING INSTRUCTIONS ALWAYS CLOSE WITH YOU!

Dear Customer,
please read these instructions carefully before using your new transport dolly for the first time!

GENERAL SAFETY INSTRUCTIONS

Safety zone: this includes the load, the direct area around the load and an adequate additional distance so that any tilting of the load does not result in personal injury or damage to property. The operating personnel must ensure that no unauthorized people are within the safety zone!



Never place hands, arms, feet, head below the load!

WARNING

Never place hands, arms, feet, head below the load!



Warning

Be careful of projecting parts or attached parts to avoid head injuries, for example!



Caution

Operating personnel must wear safety shoes with steel toe caps!



Lifting and Moving Solutions



**OPERATING AND MAINTENANCE INSTRUCTIONS No. 09 / 2011 FOR GKS-PERFEKT
TRANSPORT DOLLIES TYPE F, L, RL, TL, HF and HL**

SPECIAL SAFETY INSTRUCTIONS

Before using the GKS – Perfekt transport dollies, always check the weight of the load to be lifted and the condition of the ground. The relevant guidelines and accident prevention regulations must also be observed.

- Always check the dolly for visible damage before use.
- Do not overload transport dollies and steering dollies. Even if the load is off-center, the permissible maximum load may not be exceeded.
- Only use the stationary (type F) and steering (type L) dollies on level ground.
- On uneven ground the dollies and the load must be fastened firmly together.
- The dollies do not have an integrated brake.
- When transporting heavy goods, the speed must not exceed 2 km/h (1.25 mph).
- When using suitable towing vehicles, avoid jerky starts and do not exceed the unbraked towing load.
- Do not use on upwards or downward slopes.
- Dollies must always be parallel to each other and to the load.
- Never use Type F dollies without a connection rod. If you use the device without a connection rod the rollers can be damaged!

No guarantee or liability can be assumed for personal injury or damage to property resulting from one or more of the following causes:

- Failure to observe the operating instructions.
- Unauthorized constructional alterations
- Failure to maintain parts which are subject to wear
- Incorrect repairs
- Use of the stationary and steering dollies for any use other than that for which they are intended.

For machines with frame structures or feet which do not permit three-point support we recommend our tandem steering dollies with four-point support.

For difficult surfaces we recommend our dollies with hydraulic roller balancing system to compensate for ground unevenness of approx. ± 20 mm (0.8 inches) thereby avoiding excess loads on individual rollers.

For confined spaces we recommend our rotating dollies. Heavy loads can be rotated by 360° around their own axis.

For any questions arising before or during operation, where you are unsure how to do it, contact us for further advice.



Lifting and Moving Solutions

OPERATING AND MAINTENANCE INSTRUCTIONS No.09 / 2011 FOR GKS-PERFEKT TRANSPORT DOLLIES TYPE F, L, RL, TL, HF and HL

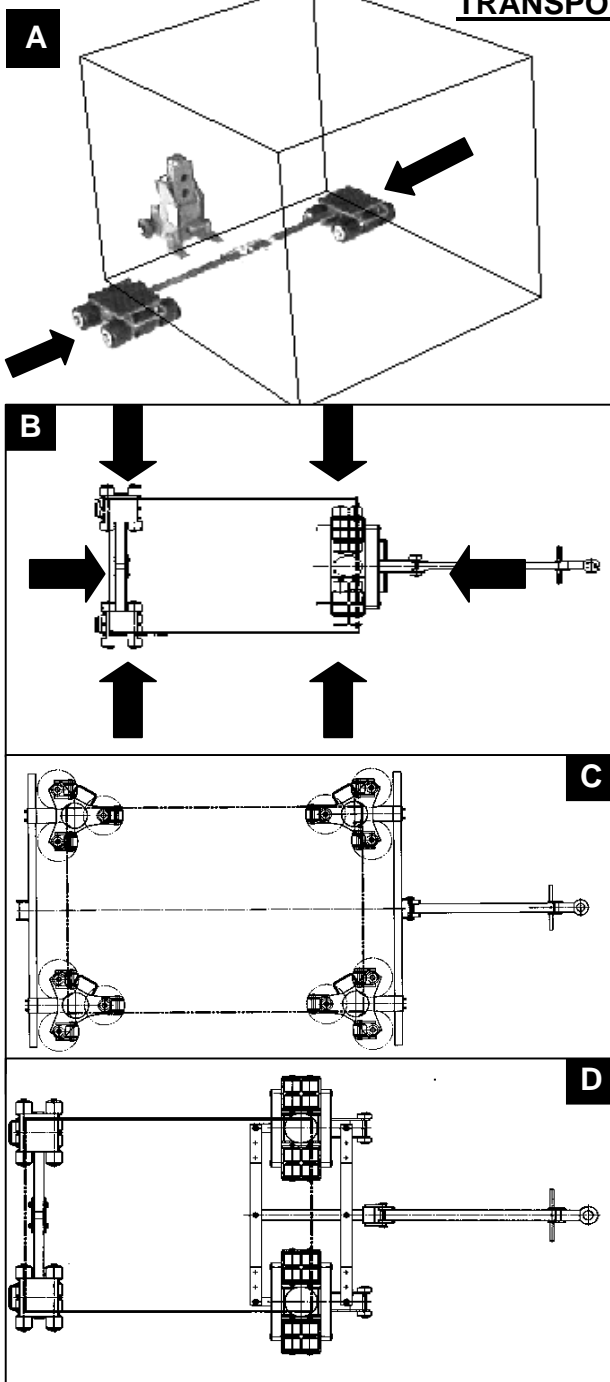

WORK STEPS

LOADING (Fig. A)

- Check the weight of the load
- Select a suitable transport dolly
- Select a suitable lifting device

We recommend our GKS-PERFEKT hydraulic lifters

- Lift the load at the rear
- First set the dollies for the required distance
- Roll the transport dolly under the load

⚠ Keep clear of the suspended load!

The support plates of the dollies must always project beyond the edge of the load.

- Lower the load slowly and gently
- Secure the dolly from rolling away before the next lift operation
- Lift the load at the front
- Roll the steering dolly under the load

⚠ Keep clear of the suspended load!

The rotation plate of the steering dolly must be centred under the load.

The steering rod must be able to move freely.

LIFTING AND SUPPORTING

See fig. B for lifting and supporting options

TRANSPORT

- Convey the load to the desired location, making sure to observe the safety instructions on page 3 and 4
- **Do not exceed the permissible rolling speed of 1.25 mph (2 km/h) !**

UNLOADING

- Secure dollies from rolling away
- Apply lifting device
- Remove the steering dolly first
- **⚠ Keep clear of the suspended load!**
- Remove the transport dolly

EXAMPLES OF FOUR-POINT SUPPORTS

Example RL2 (fig. C) Example F12/TL12 (fig.D)



Lifting and Moving Solutions

OPERATING AND MAINTENANCE INSTRUCTIONS No. 09 / 2011 FOR GKS-PERFEKT TRANSPORT DOLLIES TYPE F, L, RL, TL, HF and HL

REPAIR INSTRUCTIONS

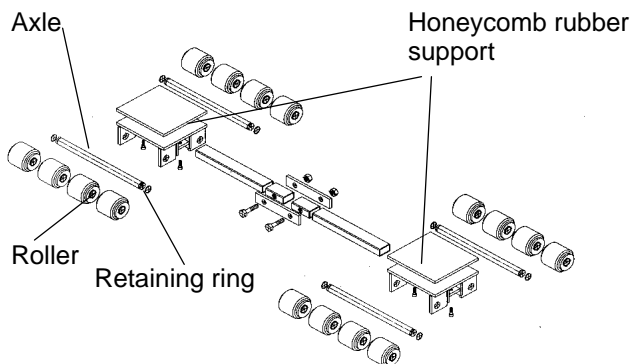

Ex: Transport stationary dolly type F12

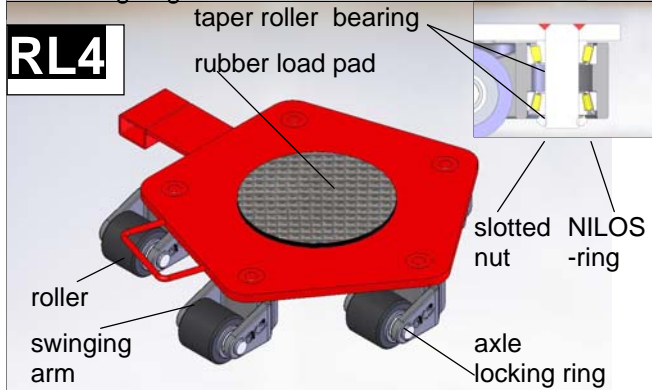
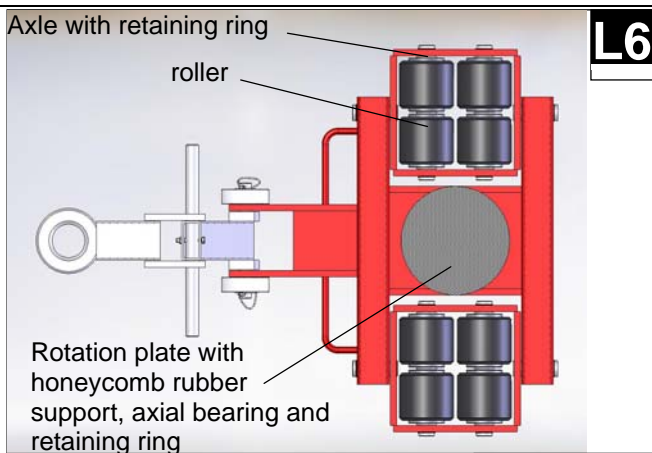

CHANGING THE ROLLERS

Remove the retaining ring at the axle

- Remove the axle
- Change the rollers
- Fit the axle
- Fasten the retaining ring

REPLACING THE RUBBER SUPPORTS

- Remove the rubber support and any adhesive residues (the surface must be free of grease and rust)
- Remove the foil on the back of the new rubber support
- Apply contact adhesive to the support surface and the roller support
- Allow to dry briefly and proceed as described in the instructions for the adhesive

REPLACING THE BALL THRUST BEARING

- Turn over the transport dolly so that it is resting on the rotation plate
- Remove the retaining ring from the rotation plate
- Lift the dolly
- Remove the ball thrust bearing
- Fit the new bearing (for dolly L3 insert the centring ring)
- Replace the dolly
- Fit the retaining ring (must engage correctly)

REPLACING THE TAPERED ROLLER BEARING

- Turn over the rotation dolly so that it is resting on the support plate
- Release the slotted nut using a hook spanner (DIN1810A size 45/50) and unscrew
- Remove the bearing seal ring
- Pull the rocker upwards and out (only possible if the bolt is not bent)
- Remove the complete tapered roller bearing
- Insert the tapered rollers symmetrically into the rocker
- Grease the bolt
- Replace the rocker
- Cover with bearing seal ring
- Tighten the slotted nut, then loosen by ½ a turn
- The rocker must not have any axial play



Lifting and Moving Solutions

OPERATING AND MAINTENANCE INSTRUCTIONS No.09 / 2011 FOR GKS-PERFEKT TRANSPORT DOLLIES TYPE F. L. RL. TL. HF and HL

OTHER INSTRUCTIONS

SERVICE, REPAIR AND ORDERING SPARE PARTS

- **Service / spare parts lists and ordering spare parts:**
- For rapid information and spare parts orders please contact

Distributed by Tri-State Rigging Equipment
 sales@tsriggingequipment.com
 www.tsriggingequipment.com
 Tel: (314) 869-7200

- **Repair**

Any maintenance and repair work necessary after years of use will be carried out rapidly and correctly by us following a cost quotation. Send the device to us.

INSPECTION

Always carry out a visual inspection **before** using the stationary and steering dollies.

- Check the welded seams
- Check for any bending of the dolly cartridge and the connection rod
- Check the roller for dirt and wear
- If the rollers are wearing unevenly, they must be replaced cartridge by cartridge

GUARANTEE

There is a 5 years guarantee on material and construction subject to correct use. Unauthorised intervention within this period shall cause the guarantee to lapse unless we have granted prior written permission. The guarantee does not apply to wearing parts

SPECIAL MODELS

Our design department will be happy to realise customised lifting and transport devices and offer solutions for the transport of all heavy goods. Feel free to contact us.

EC CONFORMITY DECLARATION

We hereby declare that the GKS-PERFEKT transport dollies types:

F1, F2,5, F3, F6, F9, F10, F12, F18, F20, F25, F30, F40, F50, F60, F100	HF15, HF25
L1, L2.5, L3, L6, L9, L10, L12, L18, L20, L25, L30, L40, L60	HL15, HL25
TL6, TL12, TL20, TL40, TL50, TL100,	RL1, RL2, RL3H, RL4

from date of manufacture 3/1994 for the internal transport of machines and heavy loads correspond to the following regulations:

- Guideline 2006/42/EC of the European Parliament and the Council dated 17nd May 2006, appendix II A

Applicable international technical standards, in particular

- DIN EN ISO 12100 : Safety of machines

Applicable national technical standards and specifications, in particular

- BGV D27
- German technical Plant and Equipment Act

Fellbach, 14.09.2011



Lifting and Moving Solutions

**OPERATING AND MAINTENANCE INSTRUCTIONS No. 09 / 2011 FOR GKS-PERFEKT
TRANSPORT DOLLIES TYPE F, L, RL, TL, HF and HL**

NEVER USE REAR DOLLIES (F MODEL) WITHOUT CONNECTING BAR

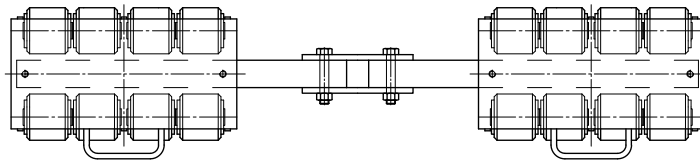

CORRECT WITH CONNECTING BAR

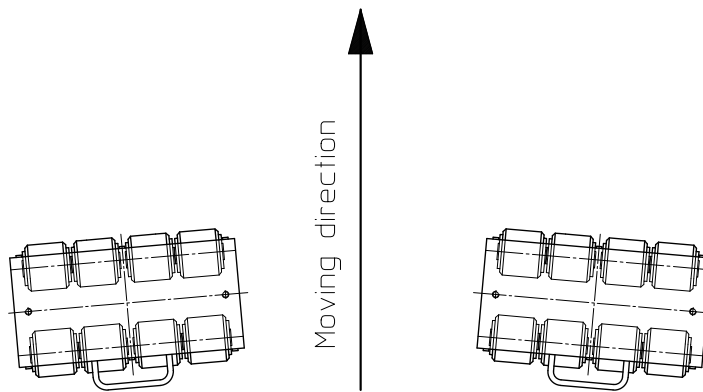

NOT CORRECT WITHOUT CONNECTING BAR

Note : The lifetime of your F dolly rollers will be shortened using them without connecting bar as lining material will get lots of side pressure.

Distributed by Tri-State Rigging Equipment
sales@tsriggingequipment.com
www.tsriggingequipment.com
Tel: (314) 869-7200