

Lifting & Spreader Beams

Model 17 - Adjustable Lifting Beam

PRODUCT FEATURES:

- Bail adjusts horizontally for lifting unbalanced loads.
- Provides clearance in low headroom applications.
- Spread adjusts in 6" increments along lifting beam.
- Shackles included.
- Optional swivel hooks available.
- Complies with ASME standards.



PRODUCT OPTIONS:

- **OPTION S** - Pair of swivel hooks

**INSTOCK
PROGRAM**

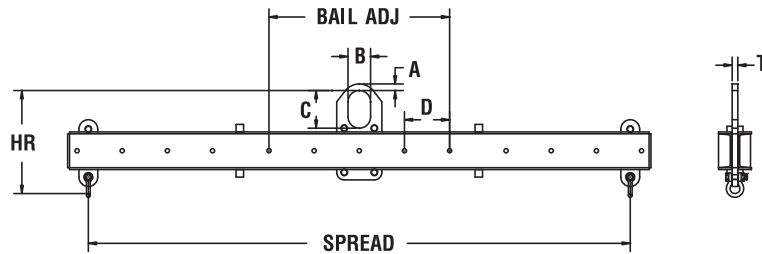

SPECIFICATIONS

Model Number	Rated Capacity (tons)	Spread (in.)		Bail Adjustment		HR Headroom (in.)	Shackle Size (tons)	Bail Dimensions (in.)				Weight (lbs.)
		Max.	Min.	Range (in.)	D (in.)			A	B	C	T	
17-1 1/4-6	1-1/4	72	36	24	3	14.7	2	1 1/2	3	5	5/8	150
17-2-6	2	72	36	24	3	14.7	2	1 1/2	3	5	5/8	155
17-4-8	4	96	54	36	6	19.8	3 1/4	2	4	7	3/4	285
17-5-10	5	120	60	36	6	22.4	4 3/4	2	4	7	1	475

Operation

BAIL ADJUSTED FOR UNBALANCED LOAD

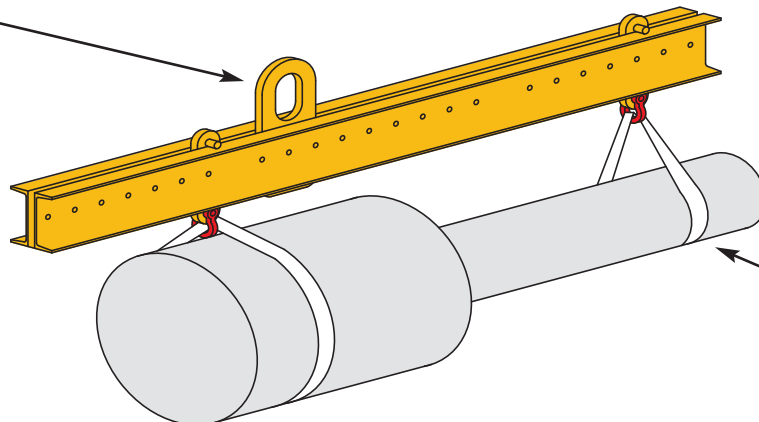

LIFT POINTS ADJUSTED FOR LOAD LENGTH